

## Replacement Parts

| DESCRIPTION                 | PART #  | DESCRIPTION                  | PART #  |
|-----------------------------|---------|------------------------------|---------|
| REBUILD KIT 1.38"           | 6690263 | BOLT KIT, .810"              | 6690271 |
| REBUILD KIT 1.75"           | 6690264 | BOLT KIT, 1.25"              | 6690270 |
| PISTON FOR 1.38"            | 6690305 | BRIDGE BOLT AND SPACER .810" | 6690272 |
| PISTON FOR 1.75"            | 6690294 | BRIDGE BOLT AND SPACER 1.25" | 6690273 |
| O-RING KIT FOR 1.38"        | 6690255 | ABUTMENT PLATES              | 6690306 |
| O-RING KIT FOR 1.75"        | 6690256 | SPEED BLEEDER KIT            | 6690284 |
| SHIM KIT FOR FORGED CALIPER | 6690257 |                              |         |

\* REBUILD KITS INCLUDES PISTONS, O-RINGS, AND ABUTMENT PLATES

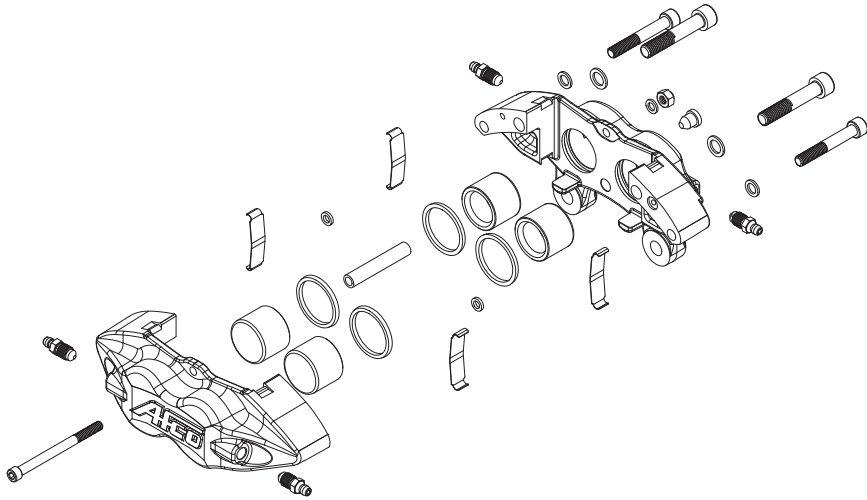

## Brake Pad Recommendations

| <b>Left Front</b>             |        | <b>Dirt Late Model</b> |             | <b>Right Front</b>            |           |
|-------------------------------|--------|------------------------|-------------|-------------------------------|-----------|
| <b>RECOMMENDED BRAKE PADS</b> |        | <b>PART #</b>          |             | <b>RECOMMENDED BRAKE PADS</b> |           |
| C1 COMPOUND                   | BETTER | 1251-1002              | C1 COMPOUND | BETTER                        | 1251-1002 |
| C2 COMPOUND                   | BEST   | 1251-2002              | C2 COMPOUND | BEST                          | 1251-2002 |
| <b>Left Rear</b>              |        | <b>Right Rear</b>      |             | <b>RECOMMENDED BRAKE PADS</b> |           |
| <b>RECOMMENDED BRAKE PADS</b> |        | <b>PART #</b>          |             | <b>RECOMMENDED BRAKE PADS</b> |           |
| C1 COMPOUND                   | BETTER | 1251-1002              | C1 COMPOUND | BETTER                        | 1251-1002 |
| C2 COMPOUND                   | BEST   | 1251-2002              | C2 COMPOUND | BEST                          | 1251-2002 |

AFCO Racing Products • 977 Hyrock Blvd. Boonville, IN 47601  
800.632.2320 • AFCORacing.com

LIT3012

# AFCO™

## F22 Forged Aluminum Caliper



Thank you for purchasing an AFco F22 forged brake caliper. The new F22 is the newest and most innovative brake caliper to join the family of AFco brake products. The F22 caliper features a forged design, larger cross bolts, a closed end bridge design, billet aluminum pistons, internal fluid passages, and one piece bleeders all designed to make the F22 the strongest, lightest, most reliable, and maintenance free caliper in the market.

### Required Tools:

- 5/8" wrench or socket
- 1/2" wrench
- 7/16" wrench or socket
- 3/16" hex wrench
- 8 mm hex wrench
- 6 mm hex wrench

### Required Hardware:

- 2-7/16" X 1 1/2" Grade 8 bolts (fine or coarse depending on caliper mounting bracket)
- 4-7/16" flat washers
- 1/8" NPT brake fitting. Line size and angle varies per application.
- Thread sealer or teflon thread tape
- AFco HTX brake fluid
- AFco brake caliper shim kit (optional - P/N 6690257)
- 2-7/16" nylock jam nuts (optional)

## ***Installation***

1. Apply thread tape or sealant to the line fitting of choice.
2. Install the fitting into the caliper. Torque to 12 ft-lbs. Over tightening the fitting can cause it to leak or break.
3. Make sure the rotor this is being used is straight, free of cracks, and has flat surfaces before installing the caliper.
4. Using two 7/16" X 1 1/2" long Grade 8 bolts and two 7/16" flat washers install the brake caliper, bolting it to the caliper mount on the spindle or rear end.

5. Finger tighten the bolt at this point since they will likely need removed. Measure from each side of the brake rotor to the caliper. If the caliper is not centered move the caliper mount to center the caliper on the rotor. If the caliper mount can not be move use AFCO's caliper shim kit or 7/16" flat washers to space the caliper away from the caliper mount to center the caliper on the rotor.

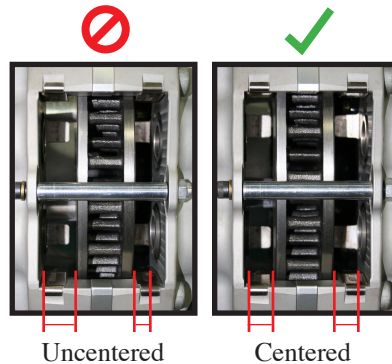

6. After the caliper has been centered on the rotor torque the 7/16" Grade 8 bolts to 20 ft-lbs.
7. Install two 7/16" jam nuts onto the bolt that comes through the caliper bracket and torque to 15 ft-lbs. (Optional)
8. Remove the brake pad retaining bolts and tube assembly. Install your AFCO brake pads or your pad of choice.
9. Replace the brake pad retaining bolt and tube. Torque the 1/4" bolt to 75 in-lbs and check that the pad spacing is the same between the inner and outer pad.
10. Connect the brake line to the fitting installed in step 2. Torque the line fitting to 100 in-lbs. Over tightening the fitting can cause the connection to leak.
11. Check all caliper half bolts for proper torque. Torque to 25 ft-lbs.
12. Check all four bleeders for proper torque. Torque to 12 ft-lbs.
13. Check all brake mounting bolts and fittings for tightness.
14. Install a wheel of you choice and check for interference between the wheel and caliper.

## ***Bleeding Procedure***

1. Ensure that all brake fittings and bleeders are tight.
2. Fill the master cylinders with AFCO HTX brake fluid for the best performance.
3. Make sure the master cylinders have been bench bled.
4. Start with the caliper the furthest distance from the master cylinders.
5. Pump the brake pedal 3 times slowly. On the last pump hold constant pressure on the pedal.
6. Place a clear plastic tube over the end of the outer bleeder that is at the highest point. Open the bleeder using a 7/16" wrench.
7. Tighten the brake bleeder and release the pedal.
8. Repeat this process until no air is present in the fluid.
9. Re-check the fluid level in the master cylinders.
10. Repeat steps 6-10 with the inner bleeder on the same caliper.
11. Clean any fluid that may have spilled on the rotors and calipers during the bleeding process.
12. Repeat steps 6-12 with each caliper starting with the next furthest away from the master cylinder and working your way closer.
13. After completing steps 6-13 pump the brake pedal 3 times to check for a firm pedal. If you do not have a firm pedal repeat the bleeding process again.

## ***Maintenance Checklist***

1. Check all caliper bolts, fittings, and brake bleeders for proper torque.
2. Inspect the bridge area for wear.
3. Check for fluid leaks at the fittings, caliper half, and bleeders.
4. Bleed the brake system each week for the best performance.